

FLEET
(rev) 7-2014

N U C R A F T

Installation Instructions

Before Beginning Installation

- Read through the entire instruction thoroughly
- A minimum of 2 people are required for this assembly
- These instructions reflect typical assemblies; They may not match your specific configuration

Required Tools & Hardware

- Drill Driver
- #2 Phillips Bit
- 1/4" Allen Wrench
- Adjustable Wrench

1



2



3

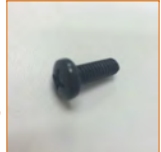

Fleet C-Leg Nesting



Fleet C-Leg Exploded

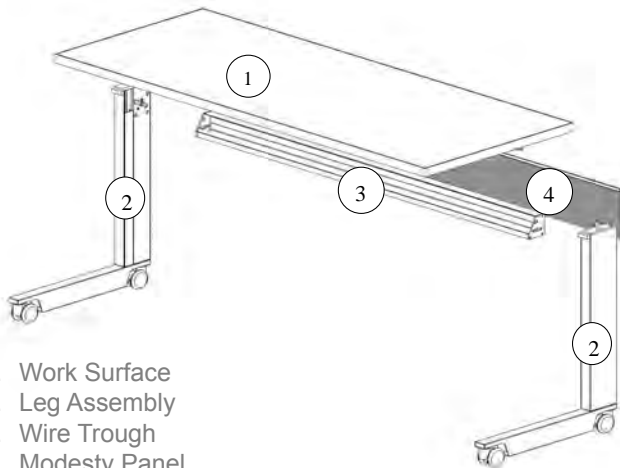

1. Work Surface
2. Leg Assembly
3. Wire Trough
4. Modesty Panel

Fleet T-Leg Nesting

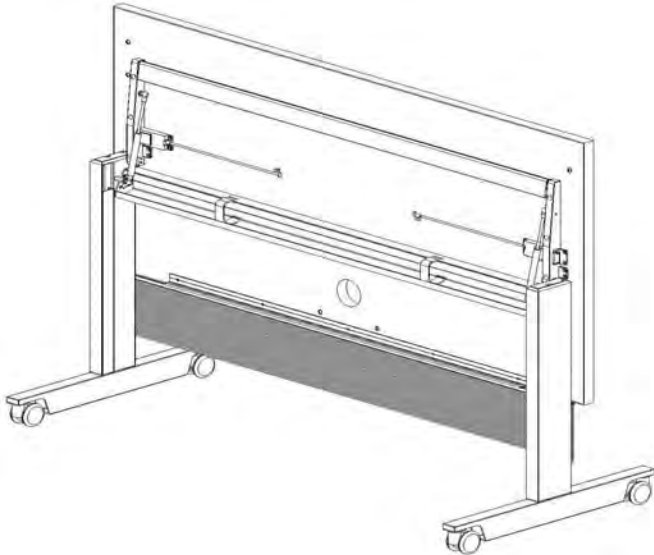

Fleet T-Leg Exploded

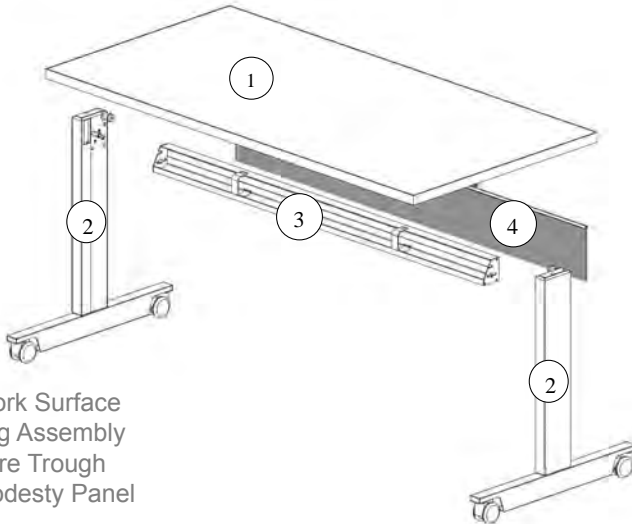

1. Work Surface
2. Leg Assembly
3. Wire Trough
4. Modesty Panel

Step 1

Attaching wire trough to legs

- On the leg assemblies, remove the front screw on the leg and loosen the back two screws 3/8"
- Lining up the slots with the 2 back screws, slide the trough into place
- Re-insert the front screw and tighten. The back screws can now be tightened as well

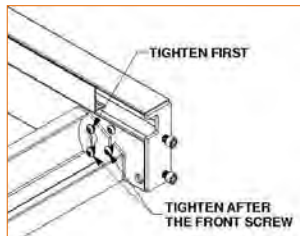
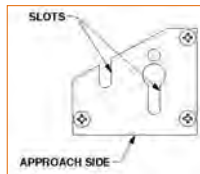
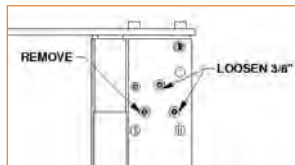

Step 2

Leg Attachment / Static

- Place the work surface face down on a clean surface
- Align the holes in the leg top plate with the inserts on the underside of the work surface
- Using supplied fasteners, secure legs to the work surface

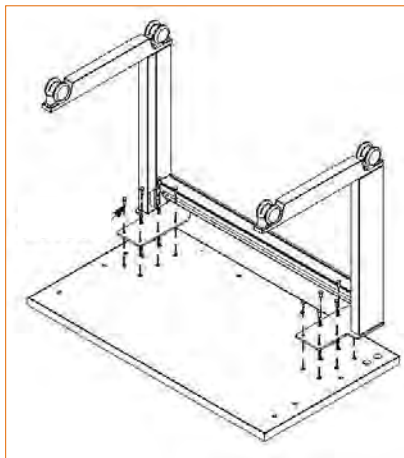

Step 2

Leg Attachment / Nesting

- Remove the shoulder bolts and acetyl bearings from the legs
- Place the work surface face down on a clean surface. Align the holes in the legs with the thru holes in the nesting arms
- Make sure there is a bearing on each side of the nesting arm, and re-attach the shoulder bolt

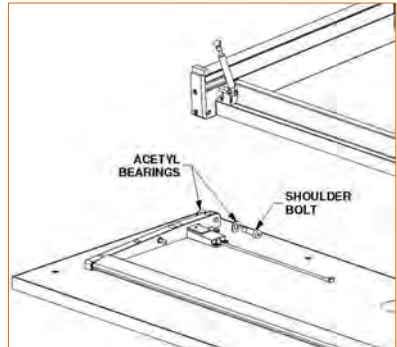

Step 3

Leg Attachment / Nesting

- With table still on the floor, pivot the legs up until the unattached end of the gas cylinder is aligned with the ball socket standoff on the leg
- Snap the gas cylinder end onto the ball socket by applying direct pressure
- Continue closing the legs until they latch into place. Flip the table to its upright position

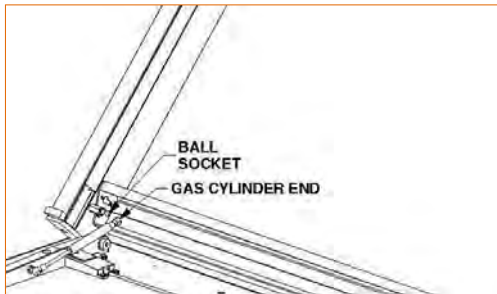

Step 4

Modesty Panel Attachment

- Attach one of the hinge pins to the under side of the table. Be sure the pin is oriented to that the screw holes are away from the edge of the surface.
- Slide one end of the modesty panel onto the attached hinge pin. Carefully holding the panel level the entire time.
- Slide the remaining pin into the groove on the modesty panel and attach.

